

# Optimization Technique for detection of signal in MIMO System

Prabhpreet Kaur Saini, Amanjot Singh  
Department of Electronics and Communication  
Lovely Professional University

**Abstract**— MIMO techniques are based on multiple antennae in receiving and transmitting signals and also used in multipath propagation for the transformation of entire channel into many independent virtual channels. In MIMO system multiple antennae can increase the spectral efficiency/ reliability of radio channel without increasing bandwidth or transmit power. Commercially, it is not feasible in case of MIMO systems. So, simple and efficient receiver that can harness MIMO architecture benefits without draining mobile receiver battery power or long time to decode transmitted symbols was required. In this paper problem of receiver design for MIMO system in spatial multiplexing scheme that is Maximum likelihood detection problem also known as NP hard combinatorial optimization problem, which need an exponential search over the space of all possible transmitted symbols in order to find closest point in Euclidean sense to received symbols, has been considered. A metaheuristic algorithm for detection of MIMO wireless system based on the Ant colony optimization (ACO) technique using MATLAB give the best solution to the problem and find the optimal path for the receivers.

**Index Terms**— ACO-ant colony optimization, CO- combinatorial optimization, MATLAB- matrix laboratory, Metaheuristic, MIMO- multiple input multiple output , NP Hard-non deterministic polynomial time hard, QAM- quadretic amplitude modulation



## 1 INTRODUCTION

In wireless mobile communication the demand for multimedia services as well as an number of subscribers is increasing briskly. As the current air interfaces are incapable of supporting the high data rates and quality of services, designers have been looking into techniques that would improve average and peak bit rates, latency, service coverage, spectral efficiency and system capacity. One of the most hopeful techniques is the use of multiple antennae at both transmitting and receiving sides of the radio channel. The use of multiple antennae helps to mitigate the impairing effects of fading. Actually MIMO model exploits the very presence of the rich scattering environment to provide diversity and improve performance of wireless channel. To harness potential diversity and multiplexing gains of MIMO system the receiver and transmitter should be optimally designed.

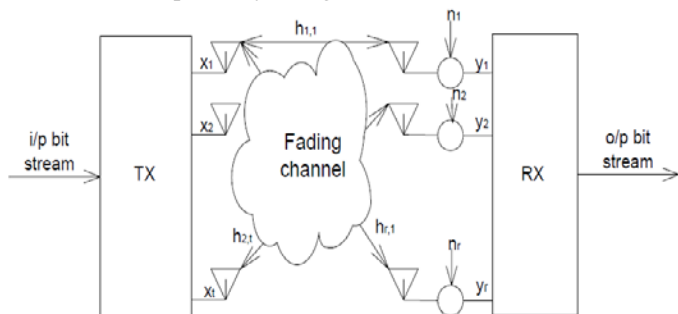

fig.1: MIMO system schematic representation

Source: [20]

- Prabhpreet Kaur Saini is currently pursuing masters degree program in electronics and communication engineering in Lovely Professional University, India, PH-9888408825. E-mail: sainiprabhpreet@gmail.com
- Amanjot Singh is Assistant Professor in Lovely Professional University, India, PH-8283837583. E-mail: AMANJOT.15848@lpu.co.in

According to Berbineau (2004), new technologies of communication and information are regarded as two key components for the transmission of systems based on applications namely video on demand, embedded surveillance, control, command and maintenance reporting, etc. The wireless systems are deployed by using multiple antennas for radiating cables or wave guides in free propagation through tunnels. It is significant for the basic wireless systems to increase high data rate and robustness and also to prevent the increase of transmitting power or transmission bandwidth [12].

According to Acan (2004) a probabilistic technique for resolving several issues which can be limited to predict better paths through graphs is referred to as the ant colony optimization algorithm. Although true ants are blind, they are capable of predicting the smallest path from sources of food to their nest by utilizing a liquid material referred to as a pheromone, which they discharge on transit route. The Ant Colony Optimization algorithm is an ant colony algorithms family member in swarm intelligence processes and it forms some metaheuristic optimizations [1].

Dorigo and Blum (2005) has mentioned that Ant Colony Optimization is also a general search technique based on population for complicating repetitive problem's solution which is affected by the pheromone track preventing real ant colonies behavior. In artificial ant colonies the ant behavior is inhibited for the evaluated solutions search to discrete optimization issues to repetitive optimization issues and to significant issues in telecommunications, such as load balancing and routing [9]. In the Ant Colony Optimization the first algorithm was targeted to search for graph's optimal path based on the ants behavior viewing for a path between their food source and colony.

The ant colony optimization is a metaheuristic algorithm of an artificial ant colony in detecting better solutions to critical discrete optimization issues. The option is to allot the resources of computation to a series of commonly simple agents that interacts stigmergy indirectly [8].

Glover and Kochenberger (2002) have described that the developed As strategy tries to simulate real ants behavior with the addition of numerous artificial features such as discrete time, visibility and memory to solve several complicate issues successfully such as the vehicle routing problem, best path planning and travelling salesman problem, even though several modifications have been applied to the Ant Colony Optimization algorithms during the past years, their major behavioral mechanisms of ant i.e. process of positive feedback explained by ants colony is still common. The algorithm of ant has several numbers of networking applications such as in electrical distribution networks and in communication networks [13].

## 2 PROBLEM REPRESENTATION

In a spatial multiplexing mode assume a  $n \times n$  multi input multiple output system with transmit symbols chosen from a complicate M-QAM constellation, the researcher needs the receiver to detect the  $t$  transmitted messages correctly using the algorithm of Ant multi input multiple output algorithm (Catreux et al, 2002) [7].

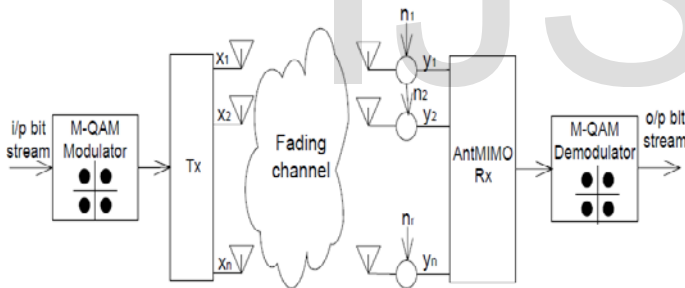

Fig.2:  $n \times n$  Multi Input Multiple Output schematic representation using a configuration of SM using Ant Multi Input Multi Output Algorithm at the receiver

Source: [2]

From the above figure the complicate  $n \times n$  Multi input multiple output system can be indicated by the model of real system of equation :

$$Y = Hx+n ; \text{-----(1)}$$

Where  $y \in R^{2n}$ ,  $H \in R^{2n \times 2n}$  with  $h_{ij} \sim N(0,0.5)$ ,  $x \in Z^{2n_{\sqrt{M}}}$ , and  $n \in R^{2n}$  with  $n_i \sim N(0,\sigma^2)$ . The detection problem of Multi Input Multiple Output is common to resolve the minimization problem of integer least-squares.

$$\min_{x \in Z^{2n_{\sqrt{M}}}} ||Y - Hx||^2 \text{-----(2)}$$

The minimization problem of integer-least squares of the equation (1) are indicated by combinatorial optimization problem  $P_{MIMO} = (f, S, \Omega)$  where  $f$  the objective function must be reduced is the Euclidean distance  $||Y - Hx||^2$ ,  $S$  is all possible transmit vectors  $x$ , and the series of constraints indicates the element integrality constraint of  $x$ , where  $Z_{\sqrt{M}} = \{0,1,\dots,\sqrt{M}\}$  (Glover and Kochenberger, 2002). The CO issue is associated to  $P_{MIMO}$  an entire tree  $T = (C,E)$  described by[13]:

- For  $n \times n$  multi input multiple output system, height  $h = 2n$ .
- $R$  a dummy node indicating a root.
- The set  $E$  indicates the corners linking nodes of parent to nodes of children.
- The finite set  $C = \{c_1, L_0, c_2, L_1, \dots, c_N, L_{N-1}\}$  indicate the tree's labeled nodes where label  $L_i$  linked with node  $c_j, L_i$  is chosen from the series  $Z_{\sqrt{M}}$  (Randall, 2004).
- Every node of parent has  $\sqrt{M}$  children when the transmit symbols are chosen from an M-QAM constellation.
- $w = \langle c_i, L_j, \dots, c_k, L_k \rangle$  path of  $2n$  length that initiates at the 1<sup>st</sup> tree level tree where  $h = 1$  and continues down the tree choosing an individual node at every level till the node of a leaf is attained is representative of probable solution to  $\hat{x} = (j, \dots, k)$  to  $P_{MIMO}$  problem (Spencer, Swindlehurst and Haardt, 2004) [18]. The below figure represents the  $P_{MIMO}$  problem tree representation for a 4QAM,  $2 \times 2$  Multi Input Multiple Output system:

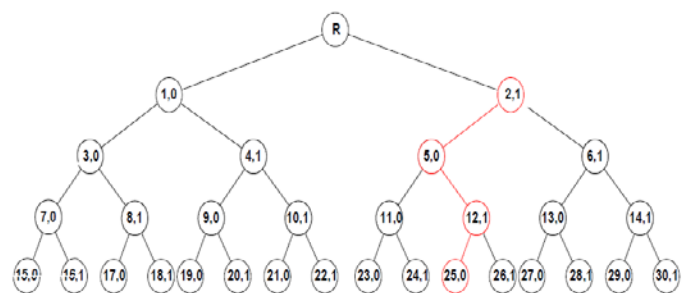

Fig.3:  $P_{MIMO}$  problem tree representation for a 4QAM,  $2 \times 2$  Multi Input Multiple Output system

Source: [8]

According to Stutzle and Hoos (2000) [19] the above figure represents the complete tree linked with a  $2 \times 2$  multi input multiple output system utilizing a 4-QAM constellation.  $w = \langle c_2, 1, c_5, 0, c_{12}, 1, c_{25}, 0 \rangle$  path for example is common to the probable solution  $\hat{x} = (1, 0, 1, 0)$ . The Ant Colony Optimization metaheuristic algorithm can be adapted easily to solve  $P_{MIMO}$  problem using this representation.

### 3 THE METAHEURISTIC APPROACH

The following algorithm illustrates the Ant Colony Optimization (ACO) metaheuristic in pseudo-code[5]. All Ant Colony  $x \in Z_{\sqrt{m}}$  optimization algorithms are described by Schedule Activities construct and its procedures:

- Construct Ants Solutions
- Update Pheromones
- Daemon Actions.

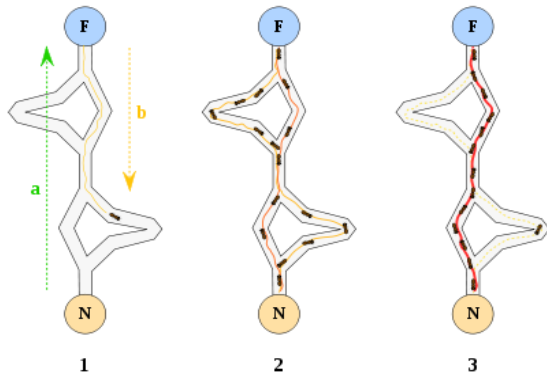

Fig.4: Basic ACO phenomenon.  
 Source: [14]

#### 3.1 The Ant Colony Optimization metaheuristic in pseudo-code:

- Procedure ACO Metaheuristic
- Schedule Activities
- Construct Ants Solutions
- Update Pheromones
- Deamon Action ( optional)
- End Schedule Activities
- End - procedure

**Construct Ants Solutions:** This allows ant colony to build solutions to the problems by moving the nodes of construction graph  $G$  by applying the stochastic local decision policy.

**Update Pheromones:** This process is responsible for modifying pheromone trails. Trail values may increase, while the ants deposit the pheromones on connections or components that they used to build the solutions. The trail values are mostly decreased by the evaporation.

**Daemon Actions:** This procedure is mainly used to implement the centralized action that was not performed by the single ants. The daemon actions will use local search algorithm and this is to improve the quality of ants' solutions. This may also include the mechanism to penalize and reward the worst and best solution by either decreasing or increasing the corresponding pheromone trail values [13].

#### 3.2 Ant System Algorithm:

Ant System was the example of Ant Colony Optimization algorithm[6]. It consisted of procedures: Construct Ants Solutions and Update Pheromones; and there is no Daemon Actions was employed.

Given, the combinatorial optimization problem

$$P = (S, f, \Omega), \text{-----(3)}$$

with the corresponding construction graph  $G = (C, L)$ . The outputs as a feasible solution  $\hat{s} \in S$  and  $\hat{s} \in \tilde{X}$ . Let  $s_p^k = \langle c_l, c_h, \dots, c_j \rangle$  will denote  $k^{\text{th}}$  ant's partially constructed solution which it walks on the construction graph  $G$ . Assume pheromones as  $\tau_{ij}$ , heuristic information as  $\eta_{ij}$  are associated with the connections  $l_{ij}$  without the loss in generality:

##### 3.2.1 Algorithm: Ant System (AS) [6] :

- Input: a CO problem instance  $P = (S, f, \Omega)$
- Initialize  $\tau_{ij}$  and  $\eta_{ij}$  ( $i, j$ )
- While termination condition not met do
- For each ant  $k=1, \dots, m$  do
- Repeat
- Choose in probability the next component  $c_i$  to add to  $s_p^k$  by means of (4.1)
- Append the chosen component  $c_i$  to the  $k^{\text{th}}$  ant's  $k$  list of visited nodes.
- Until ant  $k$  has completed its solution
- End for
- Update for pheromone values  $\tau_{ij}$  on all the connections of  $G=(C, L)$
- End while
- Output :  $s$

The probability of which ant  $k$  chooses to add the component  $c_j$  to its partially constructed solution  $s_p^k = \langle c_l, c_h, \dots, c_j \rangle$  was given by random proportional rule,

$$\rho_{ij}^k = \begin{cases} [\tau_{ij}]^\alpha [\eta_{ij}]^\beta / \sum_{l \in N_i^k} [\tau_{il}]^\alpha [\eta_{il}]^\beta, & \text{if } j \in N_i^k \\ 0, & \text{if } j \notin N_i^k \end{cases} \text{-----(4)}$$

Where  $\alpha$  and  $\beta$  are 2 user defined parameters which may determine the relative influence of pheromone value;  $N_i^k$  is neighborhood of ant  $k$  and set of allowable components  $c_j$  is to be added to  $s_p^k$ .

The pheromone of update rule used in Ant System is given by,

$$\tau_{ij} = (1 - \rho)\tau_{ij} + \sum_{k=1}^m \Delta \tau_{ij}^k \quad \forall (i, j) \in L \text{-----(5)}$$

where  $\rho \in [0,1]$  is pheromone evaporation rate and  $\Delta\tau_{ij}^k$  is amount of the pheromones that deposited by ant  $k$  on connection  $l_{ij}$ ,

$$\Delta\tau_{ij}^k = \begin{cases} F(sk) & \text{if ant } k \text{ used } l_{ij} \text{ when constructing } sk \\ 0 & \text{otherwise} \end{cases} \quad \text{-----(6)}$$

Where,  $F: S \rightarrow R^+$  is the function and it satisfies

$$f(s) < f(s') \Rightarrow F(s) \geq F(s'), \forall s \neq s' \in S \quad \text{-----(7)}$$

Where,  $P$  is the minimization problem.  $F(\cdot)$  is called as quality function.

### 4 ANT MIMO SOLUTION :

On the basis of paradigm of ACO (ant colony optimization); Ant MIMO involves three main procedures such as Construct Ants Solutions, Apply Local Search and Update Pheromones.

#### 4.1 Construct Ants Solutions:

This is regarded as first procedure in Ant MIMO. A number of 'm' ants are randomly visible at the primary level of the tree. The 'm' ants are build solutions iteratively for  $P_{MIMO}$  problem as a result it moves below the tree in parallel. The ant 'k' presently placed at parent node  $c_i$  selects to move into one of  $\sqrt{M}$  children nodes as  $c_j$  based on random proportional rule is given by [10]:

$$P_{ij}^k = \tau_{ij} / \sum l \in N_i^k \tau_{il} \quad \text{-----(8)}$$

where,  $\tau_{ij}$  – level of pheromone present at the edge of  $e_{ij}$  associating node from  $c_i$  node to  $c_j$  node;

$N_i^k$  - The set of all children of node  $c_i$ .

When an ant attains a leaf node, the completion of construction phase and the ant evaluates the cost for constructed solution  $f(x^k)$ . A single ant is able to store a list of nodes in constructing  $(x^k)$ . This type of list permits the ant to retrace its traverse path and deposit a suitable amount of pheromones with its edges to reflect in this procedure.

#### 4.2 Apply Local Search:

In this procedure, the solutions are constructed by 'm' ants to be carried in local optima by using in a 1-opt local search algorithm which is characterized by one flip neighborhood[15]. In this neighborhood, a solution  $x$  is a neighbor of a solution  $x_0$ ; where  $x$  and  $x_0$  vary exactly in one solution component.

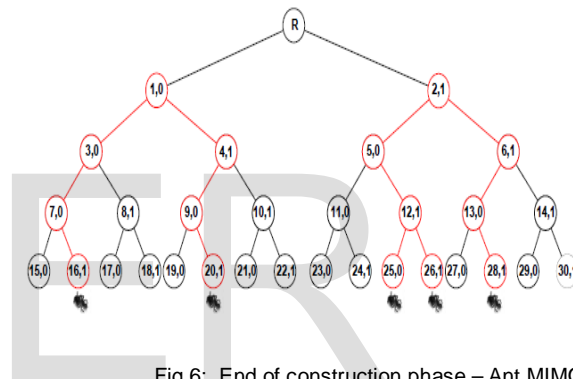

Fig.6: End of construction phase – Ant MIMO.

Source: [11]

For instance, suppose  $x = (1, 1, 1, 1)$  thus the one-flip neighborhood  $N(x)$  involves  $(0, 1, 1, 1), (1, 0, 1, 1), (1, 1, 0, 1)$  and  $(1, 1, 1, 0)$ .

#### 4.2.1 1-opt Local Search algorithm:

Input: Let us consider an ant solution  $x^k$  with equivalent path as  $w^k$ .

$$x_{LS}^k \leftarrow x^k$$

$$w_{LS}^k \leftarrow w^k \quad \forall x' \in N(x) \text{ do}$$

Compute cost of solution  $x', f(x')$ .

If  $f(x') < f(x_{LS}^k)$  then

{construction phase starts}

$$x_{LS}^k \leftarrow x^k$$

$$w_{LS}^k \leftarrow w^k$$

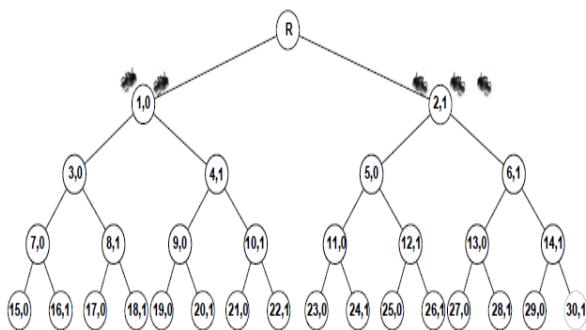

Fig.5: First level of construction tree – a colony of five ants.

Source: [11]

end if

end for

{construction phase ends}

Output:  $x_{LS}^k, w_{LS}^k$

### 4.3 Updates pheromones:

In this third procedure of Ant MIMO, by applying the global update pheromone rules of ant colony system (ACS), if only the best solution in the beginning of the algorithm  $x^{bs}$  is permitted to update the trails of pheromone on their edges equivalent to its traversed path.

$$\tau_{ij} = (1 - \rho) \tau_{ij} + \rho \Delta \tau^{bs} \forall e_{ij} \text{ transversed while building } x^{bs} \text{ -----(9)}$$

Here,  $\rho \in [0, 1]$  is the rate of evaporation and  $\Delta \tau^{bs}$  is defined by:

$$\Delta \tau^{bs} = 1/f(x^{bs}) \text{ -----(10)}$$

Above three main procedures permits the algorithm to initialize again in an array of pheromone through the procedure of Reinitialize pheromones existing only in this case when it returns a "bad solution". The term "bad solution" defines  $\hat{x}$  as its cost function  $f(\hat{x}) > fth$ , in this equation,  $fth$  denotes the value of pre computed threshold.

In this section, it obtain a pseudo code or false code description of the algorithm of Ant MIMO; where its parameter  $T$  indicates an array pheromone store the values of pheromone such as  $\tau_{ij}$  and  $x^{ib}$  indicates the best effective solution returned by ants in an iteration of single construction phase.

## 5 RESULT

The following is the result of the application of ant colony optimization algorithm in order to detect of MIMO channel using the software MATLAB

Begin Ant Colony Optimization demo  
 Number of nodes in problem = 60  
 Number of ants = 5  
 Maximum time = 500  
 Alpha (pheromone influence) = 3  
 Beta (local node influence) = 2  
 Rho (pheromone evaporation coefficient) = 0.01  
 Q (pheromone deposit factor) = 2  
 Initialing dummy graph distances  
 Initialing ants to random trails

```

1: [ 29 25 43 35 . . . 31 42 19 12 21 ] len = 218
2: [ 1 39 3 5 . . . 51 30 2 11 36 ] len = 246
3: [ 59 9 42 55 . . . 10 36 20 60 26 ] len = 267
4: [ 34 42 1 30 . . . 43 53 38 46 22 ] len = 246
5: [ 22 14 26 23 . . . 18 32 12 47 44 ] len = 283
Best initial trail length: 218
Initializing pheromes on trails
Entering UpdateAnts - UpdatePheromones loop
New best length of 207.000000 found at time 63
New best length of 205.000000 found at time 96
New best length of 199.000000 found at time 108
New best length of 196.000000 found at time 109
New best length of 190.000000 found at time 118
New best length of 176.000000 found at time 136
New best length of 175.000000 found at time 149
New best length of 170.000000 found at time 179
New best length of 158.000000 found at time 180
New best length of 146.000000 found at time 197
New best length of 142.000000 found at time 230
New best length of 137.000000 found at time 251
New best length of 136.000000 found at time 260
New best length of 128.000000 found at time 261
New best length of 126.000000 found at time 271
New best length of 121.000000 found at time 288
New best length of 115.000000 found at time 300
New best length of 113.000000 found at time 334
New best length of 111.000000 found at time 357
New best length of 109.000000 found at time 358
New best length of 108.000000 found at time 360
New best length of 98.000000 found at time 370
New best length of 95.000000 found at time 381
New best length of 92.000000 found at time 383
New best length of 90.000000 found at time 386
New best length of 84.000000 found at time 397
New best length of 83.000000 found at time 402
New best length of 78.000000 found at time 404
New best length of 77.000000 found at time 406
New best length of 76.000000 found at time 422
New best length of 74.000000 found at time 429
New best length of 70.000000 found at time 441
New best length of 66.000000 found at time 458
New best length of 65.000000 found at time 472
Time complete
Best trail found:26 17 30 53 12 9 24 6 14 47 55 48 4 19 40
1 60 3 31 42 15 23 58 36 7 28 56 32 54 57 22 41 2 34 45
5 10 33 27 59 16 39 25 20 29 21 11 8 52 13 43 49 18 44
50 37 35 38 51 46

Length of best trail found: 65.000000
End Ant Colony Optimization demo
>>
    
```

## 6 CONCLUSION

In this paper, the concept of MIMO receiver design has been taken using a spatial multiplexing system. It is equal to solve an integer least square problem i.e. NP-hard; the suboptimal detection algorithms based on polynomial complexity are employed whereas algorithms exactly like sphere decoder algorithm which solve the MIMO detection in case of optimality contain average exponential complexity. The algorithm of an Ant MIMO outperform another technique exhibit the polynomial complexity is generally used for detection of MIMO system. It belongs to the category of ACO (ant colony optimization) metaheuristic; it is a current algorithmic technique which has been motivated by the real ant's behavior to improve strategies to solve hard combinatorial optimization problems. The detection of MIMO optimal channel is an effective technique by performing an analysis of landscape over the problem of integer least squares and identifying the existence of positive correlation among fitness of solution and distance of global optimum. Through MATLAB simulation its better performance based on different  $n \times n$  MIMO system configuration by using 4-QAM constellation system have been determined. The problem of an integer least squares were created as a binary mixed integer program which was solved by Ant MIMO technique

## 7 FUTURE WORK:

The algorithm of Ant MIMO can be optimized for detecting MIMO systems by using the constellation of 4-QAM system. The often configuration of MIMO makes use of high order of constellation namely 16-QAM. The work in this paper is done on MATLAB software. The study could also be expanded using other forms of software packages and simulators such as Java, simulink, NS2 etc. The complexity of Ant MIMO being estimated to improve the local search algorithm will integrate into itself. Another characteristic feature is to configure this algorithm to detect transmissions of MIMO system codes.

## ACKNOWLEDGMENT

I am thankful to **GOD** for giving me patience, guidance and opportunities through all the people who have helped me during this paper. I would like to acknowledge Lovely Professional University for giving me this opportunity through my Masters of Technology Degree. I express my utmost gratitude to my supervisor Amanjot Singh for his excellent guidance.

## REFERENCES

- [1] Acan, A (2004), "An external memory implementation in ant colony optimization". In: Dorigo, M., Birattari, M., Blum, C., Gambardella, L.M., Mondada, F., Stutzle, T. (eds.) *Ant Colony Optimization and Swarm Intelligence: 4th International Workshop, ANTS 2004. Lecture Notes in Computer Science*, vol. 3172, pp. 73–84. Springer, Berlin.
- [2] Angus D (2006), "Ant Colony Optimization: From Biological Inspiration to an algorithmic framework," *Technical Report No. TR013*, Swinburne University of Technology, Melbourne, Australia
- [3] A. Coloni, M. Dorigo, and V. Maniezzo (1991), "Distributed optimization by ant colonies", *Proceedings of ECAL'91*, European Conference on Artificial Life, Elsevier Publishing, Amsterdam..
- [4] Bonabeau E, M. Dorigo, and G. Theraulaz, (1999): "Swarm Intelligence: From Natural to Artificial Systems", New York: *Oxford University Press*, 1999
- [5] Blum C and A. Roli, (2003): "Metaheuristics in Combinatorial Optimization: Overview and Conceptual Comparison," *ACM Computing Surveys*, Vol. 35, No. 3, 2003, pp. 268- 308.
- [6] C. Tsai, C. Tsai (2002), "A new approach for solving large traveling salesman problem using evolutionary ant rules", in *Proceeding of the 2002 International Joint Conference on Neural Networks*.
- [7] Catreux S, Erceg V, Gesbert D and Heath R W (2002), "Adaptive modulation and MIMO coding for broadband wireless data networks", *IEEE Commun. Mag.*, p 108–115.
- [8] Dorigo M and Blum C (2005), "Ant colony optimization theory: A survey. *Theoret Comput Science*";344(2–3):243–78
- [9] Dorigo M and Stutzle T (2004), "Ant Colony Optimization", *MA: MIT Press*, Cambridge.
- [10] Dreoj J and Siarry P (2004), "Continuous interacting ant colony algorithm based on dense heterarchy". *Future Generation Computer Systems*, 20(5): pp. 841–856.
- [11] Gnanasundari P and Rani SS (2010): "Performance Evaluation of Co-Operative MIMO Network Based On Ant Colony Optimization", *Journal of Computer Applications*, Vol – III, No.1, Jan - Mar 2010
- [12] G. Moniak, M. Berbineau, and J. F. Pardonche, (2004): "Robust and high data rate transmissions for security between a bus and a control center," in *VTC '2004-Fall Proceedings, vol. 2. Los Angeles, USA: IEEE*, September 2004, pp. 1377–1381
- [13] Glover F and Kochenberger G (2002), "Handbook of metaheuristics". Norwell, MA: Kluwer Academic.
- [14] [http://www.google.co.in/search?newwindow=1&q=ant%20colony%20optimization&um=1&ie=utf-8&hl=en&tbn=isch&source=og&sa=n&tab=wi&ei=jhl3uaq-doeuraf5migqdw&biw=1280&bih=588&sei=kh13uzbmf3\\_rafko4hoca#imgrc=svyfbztr9tvi-m%3a%3b4y eo7lfqycvrim%3bhttp%253a%252f%252fupload.wikimedia.org%252fwikipedia%252fcommons%252fthumb%252fa%252faf%252faco\\_branches.svg%252f400px-aco\\_branches.svg.png%3bhttp%253a%252f%252fen.wikipedia.org%252fwiki%252fant\\_colony\\_optimization\\_algorithms%3b400%3b300](http://www.google.co.in/search?newwindow=1&q=ant%20colony%20optimization&um=1&ie=utf-8&hl=en&tbn=isch&source=og&sa=n&tab=wi&ei=jhl3uaq-doeuraf5migqdw&biw=1280&bih=588&sei=kh13uzbmf3_rafko4hoca#imgrc=svyfbztr9tvi-m%3a%3b4y eo7lfqycvrim%3bhttp%253a%252f%252fupload.wikimedia.org%252fwikipedia%252fcommons%252fthumb%252fa%252faf%252faco_branches.svg%252f400px-aco_branches.svg.png%3bhttp%253a%252f%252fen.wikipedia.org%252fwiki%252fant_colony_optimization_algorithms%3b400%3b300)
- [15] M. Dorigo, V. Maniezzo, and A. Coloni, "Ant system: optimization by a colony of cooperating agents," *IEEE Transactions on System, Man, and Cybernetics*, vol. 26, pp. 29–41, February 1996.
- [16] M. Berbineau, (2001): "Existing or emerging telecommunication systems and their use in guided transports," *Synthese INRETS*, vol. 40, 2001
- [17] Rappaport T S, (1996): "Wireless Communications—Principles and Practices". Upper Saddle River, NJ: Prentice Hall.
- [18] Spencer Q H, Swindlehurst A L and Haardt M (2004), "Zero-Forcing Methods for Downlink Spatial Multiplexing in Multi-User MIMO Channels," *IEEE Trans. Sig.Proc.*, vol. 52.
- [19] Stutzle T and Hoos H H (2000), "Max-min ant system," *Future Generation of Computer Systems*, vol. 16, pp. 889–914.
- [20] Svantesson T and Swindlehurst A L (2003), "A Performance Bound for Prediction of a Multipath MIMO Channel," *Proc. 37th Asilomar Conf. Sig., Sys., and Comp.*, Session: Array Processing for Wireless Commun., Pacific Grove, CA.